



ARCA[®]

La storia del camper

COLLECTION 2015 · 16





ARCA[®]

La storia del camper



INDICE

INDEX · SOMMAIRE

MISSION

4

LA STORIA DEL CAMPER

HISTORY OF THE MOTORHOME · LE CAMPING-CAR ET SON HISTOIRE

5

PROFILATI

LOW PROFILE · PROFILÉS

P 699 GLG

Fiat Ducato X2 / 90 Special

8 - 9

P 699 GLM

Fiat Ducato X2 / 90 Special

10 - 11

P 739 GLC

Fiat Ducato X2 / 90 Special

12 - 13

MANSARDATI

COACHBUILT · CAPUCINES

M 725 GLT

Fiat Ducato X2 / 90

18 - 19





Arca Camper S.p.A. | Une Entreprise Trigano



M 725 GLM

Fiat Ducato X2 / 90

20 - 21

MOTORHOME

CLASS A · INTEGRAUX

AMERICA 1

Fiat Ducato X2 / 90 AL-KO

32 - 33

AMERICA 2

Fiat Ducato X2 / 90 AL-KO

34 - 35

AMERICA 3

Fiat Ducato X2 / 90 AL-KO

36 - 37

LA CERTEZZA DI VIAGGIARE AL SICURO

THE ASSURANCE OF SAFE TRAVEL · LA CERTITUDE DE VOYAGER EN SECURITE

50

ALBUM DI VIAGGIO

TRAVEL ALBUM · ALBUM DE VOYAGE

51



MISSION LA RICERCA SULLE MATERIE
E LO STUDIO DELLE FORME SONO IL CUORE
DELLA FILOSOFIA ARCA.
IDEE, PENSIERI, METODI ISPIRANO PROGETTI
E SONO STIMOLI COSTANTI
PER LA RICERCA DELL' ECCELLENZA.

EN

The research of materials and study of forms are the heart of Arca philosophy.
Ideas, thoughts and procedures inspire projects and are constant incentives in the pursuit
of excellence.

FR

La recherche sur les matériaux et l'étude des formes sont au cœur de la philosophie Arca.
Les idées, réflexions et méthodes inspirent les projets et sont des stimulants permanents
pour la recherche de l'excellence.



LA STORIA DEL CAMPER

HISTORY OF THE MOTORHOME · LE CAMPING-CAR ET SON HISTOIRE

Arca progetta e costruisce camper per ogni situazione climatica, per garantire ai propri clienti il più alto livello di innovazione e il più classico Italian Design. È la Passione Arca, è la semplice scelta di un veicolo di qualità superiore.



EN

Arca designs and builds motorhomes for all weather conditions, to guarantee our customers the highest level of innovation and the most classic Italian Design. It is Arca passion; it is the simple choice of a superior quality vehicle.

FR

Arca étudie et construit des camping-cars pour toutes les conditions climatiques, tout en garantissant à ses clients le plus haut niveau d'innovation, avec un Design Italien des plus classiques. C'est la passion d'Arca, le choix tout simple d'un véhicule de qualité supérieure.





PROFILATI

LOW PROFILE · PROFILÉS

Intimo e raffinato, è il veicolo ideale per chi ama viaggiare con un mezzo sicuro, solido e confortevole.

P 699 GLG

P 699 GLM

P 739 GLC

EN

Intimate and stylish, the ideal model for those who love to travel in a safe, solid and comfortable vehicle.

FR

Intime et raffiné, c'est le véhicule idéal pour les personnes qui aiment voyager avec un véhicule sûr, solide et confortable.



P 699 GLG

Chassis Fiat Ducato X2 / 90 Special



Compatto e familiare.

Living e cucina: comfort e spazio.
Letto basculante anteriore elettrico.





EN

Compact and homely.

Living area and kitchen: comfort and space.
Front electric drop-down bed.

FR

Compact et familial.

Living et cuisine: confort et espace.
Lit de pavillon avant électrique.





P 699 GLM

Chassis Fiat Ducato X2 / 90 Special



Compatto, spazioso, seducente.

Agile grazie alla lunghezza inferiore ai 7 metri.
Salotto da 140 cm contrapposto a un ampio divano laterale.
Gavone laterale per il carico dall'esterno.





EN

Compact, spacious, charming.

Agile, thanks to the length of less than 7 metres.
A large side sofa is set facing a 140 cm living room suite.
Side storage compartment for loading from the outside.

FR

Compact, spacieux, séduisant.

Maniable grâce à sa longueur inférieure à 7 mètres.
Salon de 140 cm faisant face à un grand divan latéral.
Coffre latéral pour le chargement à partir de l'extérieur.





P 739 GLC

Chassis Fiat Ducato X2 / 90 Special



Cinque stelle.

Profilato con letto matrimoniale centrale
e letto basculante elettrico anteriore.





EN
Five stars.

Low profile with central double bed and electric drop-down double bed.

FR
Cinq étoiles.

Profilé avec grand lit central et grand lit de pavillon électrique.



CARATTERISTICHE PROFILATI

LOW PROFILE FEATURES · CARACTÉRISTIQUES DES PROFILÉS

CHASSIS TUTTO DI SERIE

- Alzacristalli elettrici
- Piastre sedili girevoli
- Regolazione altezza sedili
- Doppio bracciolo
- Predisposizione autoradio
- Cup Holder
- Servosterzo
- Doppio specchio sbrin. elettrico
- Chiusura centralizzata con radiocomando
- Carreggiata allargata
- ABS
- Immobilizer
- Cerchi in acciaio 16" (ND su P739GLC)
- Cruscotto Techno
- Paraurti in tinta
- Coppe ruote integrali

PACK EVOLUTION — DI SERIE

- Clima manuale
- Cruise control
- Air Bag passeggero
- ESP con Traction +
- Quadro di bordo High Level
- Volante e cambio in pelle
- Alternatore maggiorato

CELLULA TUTTO DI SERIE

- Tende a pacchetto
- Spalliera tappezzata
- 4 nuove combinazioni di tappezzeria
- Letto elettrico posteriore (ND su P699GLG)
- Cappa aspirante in cucina
- Coprilavello
- Piano cottura 3 fuochi con piano in cristallo
- Porta spezie
- Top cucina in similcorian
- Top cucina con illuminazione LED nel bordo
- Illuminazione led sopra pensili
- Interruttori in finitura cromata
- Maniglia di accesso con LED
- Specchio su zona ingresso
- Luci notturne Blu
- Combi 6
- Comando CP Plus
- Piatto doccia in VTR
- Kit golfari in garage
- N°2 Dispenser per sapone in doccia
- Pedana in legno nel box doccia
- Appendiabiti

EN

Fully equipped chassis as standard

Electric windows · Swivel seats · Seat height adjusters · Dual armrest · Sound system ready · Cup holder · Power steering · Electric defrosting dual mirror · Central locking with remote control · Extra wide track · ABS · Immobilizer · 16" Steel wheels (not available on P739GLC) · Techno dashboard · Self-coloured bumper · Integral wheel trims

Evolution pack as standard — Manual air conditioning · Cruise control · Passenger air bag · ESP with Traction + · High level instrument cluster · Leather steering wheel and gear stick · Powerful alternator

Fully equipped living area as standard

Roman blinds · Upholstered backrest · Four new combinations of upholstery · Electric rear bed (not available on P699GLG) · Extractor hood in the kitchen · Sink cover · 3-burner stove with glass top · Spice rack · Corian-type kitchen countertop · Kitchen top with LED edge lighting · LED lighting above wall units · Chrome finish switches · Access handle with LED lighting · Entrance area mirror · Blue night lights · Combi 6 · CP Plus control panel · FG shower tray · Eyebolt kit in garage · Two soap dispensers in shower · Wooden platform in shower cubicle · Coat rack

FR

Châssis entièrement de série

Lève-vitres électriques · Socles de sièges pivotants · Réglage de la hauteur des sièges · Accoudoir double · Pré-équipement autoradio · Porte-gobelet · Direction assistée · Double rétroviseur à dégivrage électrique · Fermeture centralisée avec télécommande radio · Voie large · ABS · Dispositif d'immobilisation · Jantes en acier 16" (ND sur P739GLC) · Plaque de bord Techno · Pare-chocs teintés · Enjoliveurs intégraux

Pack évolution de série — Climatisation manuelle · Régulateur de vitesse · Airbag passager · ESP avec Traction + · Plaque de bord haut de gamme · Volant et levier de vitesse avec habillage cuir · Alternateur renforcé

Cellule entièrement de série

Stores intérieurs à panneaux · Hayon recouvert de moquette · 4 nouvelles combinaisons de moquette · Lit électrique arrière (ND sur P699GLG) · Hotte aspirante à la cuisine · Couvercle d'évier · Plan de cuisson en verre à 3 feux · Étagère à épices · Plan de travail cuisine en résine type Corian® · Plan de travail cuisine avec éclairage LED au bord · Éclairage par LED sur modules suspendus · Interrupteurs finition chromée · Poignée d'accès à LED · Miroir sur la zone d'entrée · Lumières d'ambiance bleues · Combi 6 · Commande CP Plus · Bac à douche en résine de verre · Kit anneaux d'arrimage dans l'espace de rangement · 2 distributeurs de savon pour la douche · Caillebotis en bois dans la cabine de douche · Tringles de penderie

P 699 GLG

Chassis Fiat Ducato X2 / 90 Special

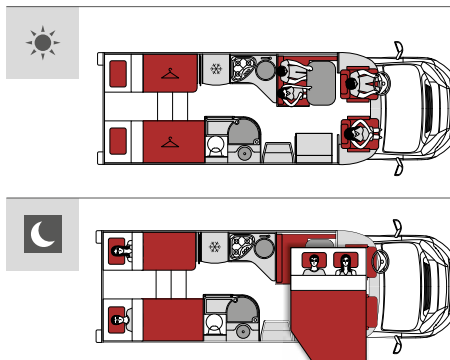

CILINDRATA - DISPLACEMENT - CYLINDRÉE	2,3 / 3,0
POTENZA - POWER - PUISSANCE	130 - 150 / 180
LUNGHEZZA - LENGTH - LONGUEUR	699
LARGHEZZA - WIDTH - LARGEUR	235
ALTEZZA - HEIGHT - HAUTEUR	285
POSTI OMOLOGATI - APPROVED SEATS - PLACES HOMOLOGUÉES	4 - 5 OPT
POSTI LETTO - NUMBER OF BEDS - PLACES DE COUCHAGE	4
SPESSORE PARETI - WALL THICKNESS - ÉPAISSEUR DES CLOISONS	43
RIVESTIMENTO PARETI / TETTO WALL / ROOF COVERING - REVÊTEMENT DES CLOISONS / DU TOIT	ALUFIBER / VETRORESINA - POLYESTER ALUFIBER / FIBREGLOSS - POLYESTER FIBRE D'ALUMINIUM / RÉSINE DE VERRE - POLYESTER
ISOLAMENTO PARETI - WALL INSULATION - ISOLATION DES CLOISONS	STYROFOAM

P 699 GLM

Chassis Fiat Ducato X2 / 90 Special

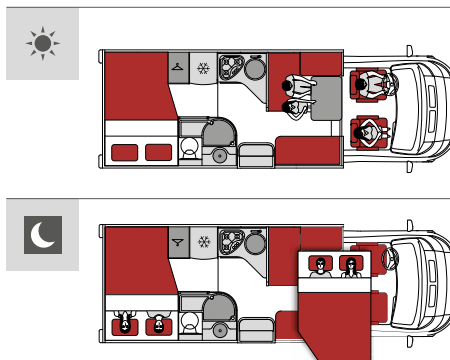

CILINDRATA - DISPLACEMENT - CYLINDRÉE	2,3 / 3,0
POTENZA - POWER - PUISSANCE	130 - 150 / 180
LUNGHEZZA - LENGTH - LONGUEUR	699
LARGHEZZA - WIDTH - LARGEUR	235
ALTEZZA - HEIGHT - HAUTEUR	285
POSTI OMOLOGATI - APPROVED SEATS - PLACES HOMOLOGUÉES	4 - 5 OPT
POSTI LETTO - NUMBER OF BEDS - PLACES DE COUCHAGE	4
SPESSORE PARETI - WALL THICKNESS - ÉPAISSEUR DES CLOISONS	43
RIVESTIMENTO PARETI / TETTO WALL / ROOF COVERING - REVÊTEMENT DES CLOISONS / DU TOIT	ALUFIBER / VETRORESINA - POLYESTER ALUFIBER / FIBREGLOSS - POLYESTER FIBRE D'ALUMINIUM / RÉSINE DE VERRE - POLYESTER
ISOLAMENTO PARETI - WALL INSULATION - ISOLATION DES CLOISONS	STYROFOAM

P 739 GLC

Chassis Fiat Ducato X2 / 90 Special

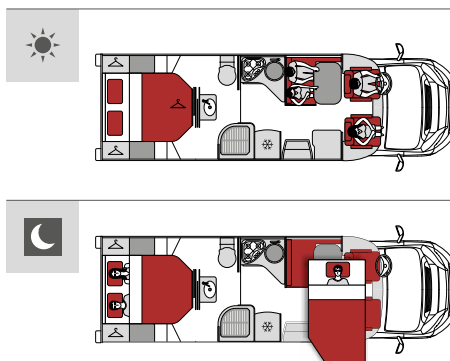

CILINDRATA - DISPLACEMENT - CYLINDRÉE	2,3 / 3,0
POTENZA - POWER - PUISSANCE	130 - 150 / 180
LUNGHEZZA - LENGTH - LONGUEUR	738
LARGHEZZA - WIDTH - LARGEUR	235
ALTEZZA - HEIGHT - HAUTEUR	285
POSTI OMOLOGATI - APPROVED SEATS - PLACES HOMOLOGUÉES	4 - 5 OPT
POSTI LETTO - NUMBER OF BEDS - PLACES DE COUCHAGE	3
SPESSORE PARETI - WALL THICKNESS - ÉPAISSEUR DES CLOISONS	43
RIVESTIMENTO PARETI / TETTO WALL / ROOF COVERING - REVÊTEMENT DES CLOISONS / DU TOIT	ALUFIBER / VETRORESINA - POLYESTER ALUFIBER / FIBREGLOSS - POLYESTER FIBRE D'ALUMINIUM / RÉSINE DE VERRE - POLYESTER
ISOLAMENTO PARETI - WALL INSULATION - ISOLATION DES CLOISONS	STYROFOAM





MANSARDATI

COACHBUILT · CAPUCINES

I Mansardati Arca rispondono alle esigenze della famiglia in viaggio: grandi spazi di carico a volumetria variabile, per assicurare il massimo del piacere del turismo itinerante.

M 725 GLT

M 725 GLM

EN

Arca coachbuilt motorhomes meet the needs of the travelling family. Large cargo space with variable volume to ensure the maximum enjoyment from travelling holidays.

FR

Les capucines Arca répondent aux exigences de la famille en voyage: grands espaces de chargement à volume variable pour que le tourisme itinérant offre un maximum d'agrément.



M 725 GLT

Chassis Fiat Ducato X2 / 90



Nuova idea di spazio.

Progettato alla ricerca del massimo comfort per la famiglia.





EN

A new take on space.

Designed to achieve the maximum in comfort for the family.

FR

Une conception nouvelle de l'espace.

Conçu pour offrir un maximum de confort à la famille.





M 725 GLM

Chassis Fiat Ducato X2 / 90



Evoluzione di fascino e concretezza.

Un veicolo con grande garage e ampi spazi per la famiglia dinamica.





EN
The evolution of beauty and practicality.

A vehicle with a large garage and ample space for the dynamic family.

FR
Évolution de l'attrait et de l'esprit concret.

Un véhicule avec un grand espace de rangement et de larges espaces pour une famille dynamique.



CARATTERISTICHE MANSARDATI

COACHBUILT FEATURES · CARACTÉRISTIQUES DES CAPUCINES

CHASSIS TUTTO DI SERIE

- Alzacristalli elettrici
- Piastre sedili girevoli
- Regolazione altezza sedili
- Doppio bracciolo
- Predisposizione autoradio
- Cup Holder
- Servosterzo
- Doppio specchio sbrin. elettrico
- Chiusura centralizzata con radiocomando
- Carreggiata allargata
- ABS
- Immobilizer
- Cerchi in acciaio 16"
- Cruscotto Techno
- Paraurti in tinta
- Coppe ruote integrali

PACK EVOLUTION — DI SERIE

- Clima manuale
- Cruise control
- Air Bag passeggero
- ESP con Traction +
- Quadro di bordo High Level
- Volante e cambio in pelle
- Alternatore maggiorato

CELLULA TUTTO DI SERIE

- Tende a pacchetto
- Spalliera tappezzata
- 4 nuove combinazioni di tappezzeria
- Letto elettrico posteriore
- Cappa aspirante in cucina
- Coprilavello
- Piano cottura 3 fuochi con piano in cristallo
- Porta spezie
- Top cucina in similcorian
- Top cucina con illuminazione LED nel bordo
- Illuminazione led sopra pensili
- Interruttori in finitura cromata
- Maniglia di accesso con LED
- Specchio su zona ingresso
- Luci notturne Blu
- Combi 6
- Comando CP Plus
- Piatto doccia in VTR
- Kit golfari in garage
- N°2 Dispenser per sapone in doccia
- Pedana in legno nel box doccia
- Appendiabiti

EN

Fully equipped chassis as standard

Electric windows · Swivel seats · Seat height adjusters · Dual armrest · Sound system ready · Cup Holder · Power steering · Electric defrosting dual mirror · Central locking with remote control · Extra wide rear track · ABS · Immobilizer · 16" Steel wheels · Techno dashboard · Self-coloured bumper · Integral wheel trims

Evolution pack as standard — Manual air conditioning · Cruise control · Passenger air bag · ESP with Traction + · High level instrument cluster · Leather steering wheel and gear stick · Powerful alternator

Fully equipped living area as standard

Roman blinds · Upholstered backrest · Four new combinations of upholstery · Electric rear bed · Extractor hood in the kitchen · Sink cover · 3-burner stove with glass top · Spice rack · Corian-type kitchen countertop · Kitchen top with LED edge lighting · LED lighting above wall units · Chrome finish switches · Access handle with LED lighting · Entrance area mirror · Blue night lights · Combi 6 · CP Plus control panel · FG shower tray · Eyebolt kit in garage · Two soap dispensers in shower · Wooden platform in shower cubicle · Coat rack

FR

Châssis entièrement de série

Lève-vitres électriques · Socles de sièges pivotants · Réglage de la hauteur des sièges · Accoudoir double · Pré-équipement autoradio · Porte-gobelet · Direction assistée · Double rétroviseur à dégivrage électrique · Fermeture centralisée avec télécommande radio · Voie large · ABS · Dispositif d'immobilisation · Jantes en acier 16" · Plaque de bord Techno · Pare-chocs tintés · Enjoliveurs intégraux

Pack évolution de série — Climatisation manuelle · Régulateur de vitesse · Airbag passager · ESP avec Traction + · Plaque de bord haut de gamme · Volant et levier de vitesse avec habillage cuir · Alternateur renforcé

Cellule entièrement de série

Stores intérieurs à panneaux · Hayon recouvert de moquette · 4 nouvelles combinaisons de moquette · Lit électrique arrière · Hotte aspirante à la cuisine · Couvercle d'évier · Plan de cuisson en verre à 3 feux · Étagère à épices · Plan de travail cuisine en résine type Corian® · Plan de travail cuisine avec éclairage LED au bord · Éclairage par LED sur modules suspendus · Interrupteurs finition chromée · Poignée d'accès à LED · Miroir sur la zone d'entrée · Lumières d'ambiance bleues · Combi 6 · Commande CP Plus · Bac à douche en résine de verre · Kit anneaux d'arrimage dans l'espace de rangement · 2 distributeurs de savon pour la douche · Caillebotis en bois dans la cabine de douche · Tringles de penderie

M 725 GLT

Chassis Fiat Ducato X2 / 90

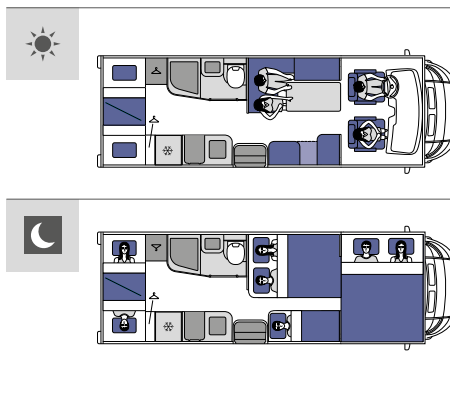

CILINDRATA · DISPLACEMENT · CYLINDRÉE	2,3 / 3,0
POTENZA · POWER · PUISSANCE	130 - 150 / 180
LUNGHEZZA · LENGTH · LONGUEUR	725
LARGHEZZA · WIDTH · LARGEUR	235
ALTEZZA · HEIGHT · HAUTEUR	315
POSTI OMOLOGATI PLACES CARTE GRISE · POSTI OMOLOGATI	4 / 5 OPT* * in fase di omologazione at the approval stage en phase d'homologation
POSTI LETTO · NUMBER OF BEDS · PLACES DE COUCHAGE	6 + 1
SPESSORE PARETI · WALL THICKNESS · ÉPAISSEUR DES CLOISONS	43
RIVESTIMENTO PARETI / TETTO WALL / ROOF COVERING · REVÊTEMENT DES CLOISONS / DU TOIT	ALUFIBER / VETRORESINA · POLYESTER ALUFIBER / FIBREGLOSS · POLYESTER FIBRE D'ALUMINIUM / RÉSINE DE VERRE - POLYESTER
ISOLAMENTO PARETI · WALL INSULATION · ISOLATION DES CLOISONS	STYROFOAM

M 725 GLM

Chassis Fiat Ducato X2 / 90

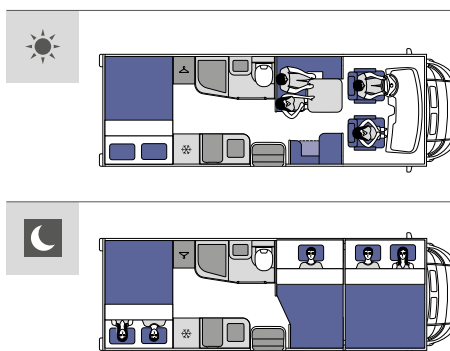

CILINDRATA · DISPLACEMENT · CYLINDRÉE	2,3 / 3,0
POTENZA · POWER · PUISSANCE	130 - 150 / 180
LUNGHEZZA · LENGTH · LONGUEUR	725
LARGHEZZA · WIDTH · LARGEUR	235
ALTEZZA · HEIGHT · HAUTEUR	315
POSTI OMOLOGATI PLACES CARTE GRISE · POSTI OMOLOGATI	4 / 5 OPT* * in fase di omologazione at the approval stage en phase d'homologation
POSTI LETTO · NUMBER OF BEDS · PLACES DE COUCHAGE	5
SPESSORE PARETI · WALL THICKNESS · ÉPAISSEUR DES CLOISONS	43
RIVESTIMENTO PARETI / TETTO WALL / ROOF COVERING · REVÊTEMENT DES CLOISONS / DU TOIT	ALUFIBER / VETRORESINA · POLYESTER ALUFIBER / FIBREGLOSS · POLYESTER FIBRE D'ALUMINIUM / RÉSINE DE VERRE - POLYESTER
ISOLAMENTO PARETI · WALL INSULATION · ISOLATION DES CLOISONS	STYROFOAM



QUALITÀ INTERNI

QUALITY INTERIORS · QUALITE A L'INTERIEUR



Rivestimenti design, eleganti e resistenti.

EN
Designer upholstery, elegant and hard-wearing.

FR
Revêtements design, élégants et résistants.



Stivaggio: capienza e stile.

EN
Storage: capacity and style.

FR
Arrimage: capacité et style.



Materassi in schiuma di lattice e reti a doghe in legno.

EN
Latex foam mattresses and wooden slatted frames.

FR
Matelas en mousse de latex et sommiers à lattes de bois.



Numerose finestre e oblò per areare e avere luce, sempre.

EN
Lots of windows and rooflights for continuous ventilation and light.

FR
Nombreuses fenêtres et lanterneau pour l'aération et l'éclairage permanents.



Vetroresina, laminati compositi e acciaio: igiene e robustezza.

EN

Fibreglass, composite laminates and steel: hygiene and strength.

FR

Résine de verre, laminés composites et acier: hygiène et robustesse.

Cucine: pratiche, robuste e ben equipaggiate.

EN

Kitchens: practical, robust and well equipped.

FR

Cuisines: pratiques, robustes et bien équipées.

Le mansarde in vetroresina Arca offrono le massime prestazioni: i pannelli isolanti, il rivestimento in materiali compositi e la circolazione nell'intercapedine dell'aria canalizzata proteggono dal freddo, dal caldo e dai rumori esterni.

Le tre finestre e l'oblò assicurano luminosità e costante ricambio d'aria.



EN

Arca fibreglass over cab bed areas offer maximum performance: insulating panels, coverings in composite materials and cavity circulation of ducted air protect against cold, heat, and external noise. The three windows and rooflight ensure brightness and constant air exchange.

1. fibreglass angle profile - 2. fibreglass moulding - 3. wooden supporting structure - 4. fibreglass covering - 5. insulating panels - 6. interior wooden panelling

Light, space and natural ventilation

FR

Les capucines en résine de verre Arca offrent les prestations maximales: les panneaux isolants, le revêtement en matériaux composites et la circulation de l'air pulsé dans la double paroi protègent du froid, du chaud et des bruits extérieurs. Les trois fenêtres et le lanterneau procurent luminosité et aération permanente.

1. profilé d'angle en résine de verre - 2. coque en résine de verre - 3. structure portante en bois - 4. revêtement en résine de verre - 5. panneaux isolants - 6. panneaux de finition internes en bois

Lumière, espace et ventilation naturelle



QUALITÀ ESTERNI: SCOCHE

QUALITY EXTERIORS: BODY · QUALITE A L'EXTERIEUR: OSSATURES



PIÙ isolamento acustico

PIÙ isolamento termico

PIÙ resistenza meccanica = sicurezza

1 **ALUFIBER**

Alluminio + VTR: estetica, isolamento termico e acustico, protezione dai raggi UV, resistente all'ingiallimento. Alta resistenza alla grandine e agli urti.

2 **STYROFOAM**

Estruso a cellula chiusa: stabilità, rigidità strutturale, alto coefficiente di isolamento termico e acustico.

3 **PROFILI IN RESINA COMPOSITA**

4 **VETRORESINA**

Foglio unico in VTR: migliora la rigidità strutturale del sandwich.

EN

MORE soundproofing · **MORE** thermal insulation · **MORE** mechanical strength = safety

1. **Alufiber** Aluminium + FG: aesthetics, thermal insulation and soundproofing, protection from UV rays, resistance to yellowing. High resistance to hailstones and shocks. - 2. **Styrofoam** Closed-cell extruded: stability, structural rigidity, high thermal insulation and soundproofing coefficient. - 3. **Composite resin profiles** - 4. **Fibreglass** One sheet FG: improves the structural rigidity of the sandwich.

FR

MEILLEURE isolation acoustique · **MEILLEURE** isolation thermique · **MEILLEURE** résistance mécanique = sécurité

1. **Fibre d'aluminium** Aluminium + résine de verre: esthétique, isolation thermique et acoustique, protection contre les rayons UV, résistance au jaunissement. Haute résistance à la grêle et aux chocs. - 2. **Styrofoam** Polystyrène extrudé à cellules fermées: stabilité et rigidité de la structure, coefficient d'isolation thermique et acoustique élevé. - 3. **Profilés en résine composite** - 4. **Résine de verre** Feuille en résine de verre: améliore la rigidité de structure du sandwich.



QUALITÀ ESTERNI: PAVIMENTO

QUALITY EXTERIORS: FLOOR · QUALITE A L'EXTERIEUR: SOLS

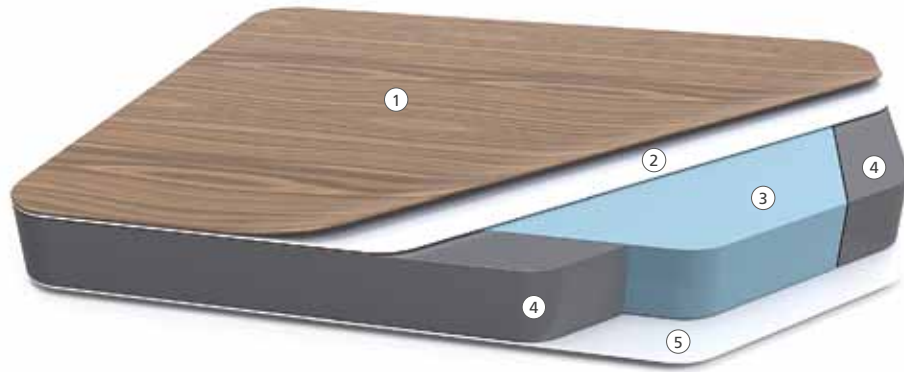

PAVIMENTO IN VTR

Protezione e resistenza in estate e in inverno.

- 1 **TAPPETO IN PVC**
- 2 **VETRORESINA**
- 3 **STYROFOAM**
- 4 **PROFILI IN RESINA COMPOSITA**
- 5 **VETRORESINA**

EN
FG FLOOR

Protection and strength in summer and winter.

1. PVC carpet - 2. Fibreglass - 3. Styrofoam - 4. Composite resin profiles - 5. Fibreglass

FR
PLANCHER EN RÉSINE DE VERRE

Protection et résistance en été comme en hiver.

1. Tapis en PVC - 2. Résine de verre - 3. Styrofoam - 4. Profilés en résine composite - 5. Résine de verre



SISTEMI

SYSTEMS · SYSTÈMES

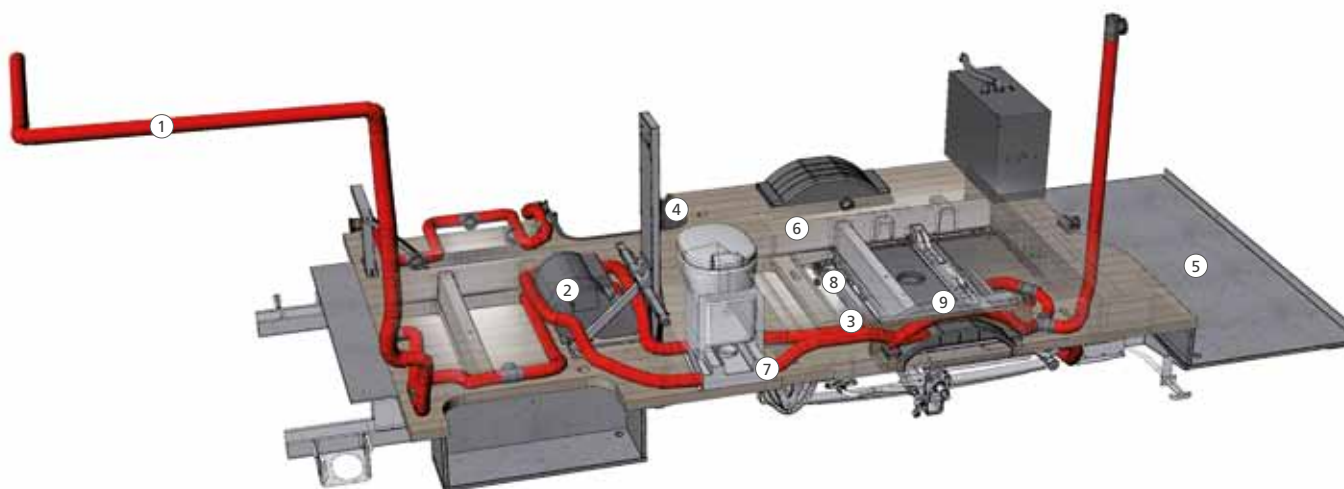

- 1 Riscaldamento perimetrale mansarda (solo classe m)
- 2 Combi in posizione centrale: ottimizza la distribuzione dell'aria in tutti gli ambienti del camper
- 3 Diffusori aria capillare all'interno cellula
- 4 Bocchetta anti-condensa per vano porta
- 5 Garage/gavoni posteriori riscaldati
- 6 Piatto doccia in VTR con doppia piletta di scarico
- 7 Serbatoio di recupero coibentato
- 8 Tubi rigidi scarico acque cucina
- 9 Sistema monocontrol di serie

EN

1. Over cab perimeter heating (only Class M) - 2. Combi in central position: optimizes air distribution in all areas of the motorhome - 3. Widespread air diffusers inside the living area - 4. Anti-condensation vent for door aperture - 5. Heated garage / rear storage compartments - 6. FG shower tray with double drain - 7. Insulated recovery tank - 8. Rigid kitchen water drainage pipes - 9. Monocontrol system as standard

FR

1. Chauffage périphérique de la capucine (seulement en classe m) - 2. Combi en position centrale: optimise la distribution de l'air, quel que soit l'environnement du camping-car - 3. Diffuseurs de jets d'air à l'intérieur de la cellule - 4. Buse anti-condensation pour ouverture de porte - 5. Espace de rangement / coffres arrière chauffés - 6. Bac à douche en résine de verre avec double bonde d'évacuation - 7. Réservoir de récupération calorifugé - 8. Tuyaux rigides d'évacuation des eaux de la cuisine - 9. Système mono-contrôle de série



STILE E ARREDO

STYLE AND DECOR · STYLE ET AMÉNAGEMENTS

MOBILIO

FURNITURE · MOBILIER



NOYER IMPERIAL



ALABAMA CHERRY

TAPPEZZERIA

UPHOLSTERY · REMBOURRAGE



VENERE IVORY



VENERE BLUE



VENERE CREAM



VENERE HAZEL

Massima personalizzazione d'arredo:
qualità stile e ricerca per viaggiare sempre nel massimo comfort.

EN

Maximum customization of decor:
quality, style and research to always travel in the utmost comfort.

FR

Personnalisation maximale du mobilier:
qualité du style et recherche pour voyager en tout temps avec un maximum de confort.





MOTORHOME

CLASS A · INTÉGRAUX

I motorhome sono il simbolo distintivo dei viaggiatori più esperti ed esigenti.
Massima espressione dello stile Arca.

AMERICA 1

AMERICA 2

AMERICA 3

EN

Class A are the distinctive symbol of the most experienced, discerning travellers.
The ultimate expression of Arca style.

FR

Les camping-cars intégraux sont le symbole distinctif des voyageurs connaisseurs les plus exigeants.
L'expression ultime du style Arca.



AMERICA 1

Chassis Fiat Ducato X2 / 90 AL-KO



Ambienti progettati per una nuova idea di viaggio.
Il massimo del comfort e del relax per sentirsi sempre a casa.
Letto basculante elettrico anteriore.



EN

Environments designed for a new concept of travel.
Maximum comfort and relaxation to always feel at home.
Front electric drop-down bed.

FR

Ambiance étudiée pour une nouvelle conception
du voyage.
Le maximum de confort et de détente pour se sentir
toujours comme à la maison.
Lit de pavillon avant électrique.





AMERICA 2

Chassis Fiat Ducato X2 / 90 AL-KO



Abitabilità e vivibilità chiare e distinte,
con letto matrimoniale centrale, in perfetto stile nautico.
Letto basculante elettrico anteriore.





EN
Clear and distinct habitability and livability,
with central double bed,
in perfect nautical style.
Front electric drop-down bed.

FR
Habitabilité et qualité de vie claires et précises,
avec grand lit central, dans le plus pur style
nautique.
Lit de pavillon avant électrique.



AMERICA 3

Chassis Fiat Ducato X2 / 90 AL-KO



Una filosofia progettuale innovativa,
con la distribuzione di letti gemelli posteriori,
senza perdere il garage. Letto basculante elettrico anteriore.



EN

An innovative design philosophy has led to the arrangement of the rear twin beds without losing the garage. Front electric drop-down bed.

FR

Un concept innovant, avec la distribution de lits jumeaux à l'arrière, sans nuire à l'espace de rangement. Lit de pavillon avant électrique.





CARATTERISTICHE MOTORHOME

CLASS A FEATURES · CARACTÉRISTIQUES DES CAMPING-CARS INTÉGRAUX

CHASSIS DI SERIE

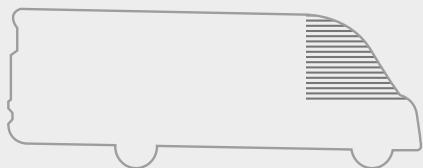

- Quadro di bordo high level
- Doppio air bag
- Cruise control
- Radio high level con navigatore
- Condizionatore manuale
- Cruscotto lounge
- Comandi al volante
- Telecamera con display integrato nel cruscotto Fiat

EN

Standard chassis

- High level instrument cluster
- Double air bag
- Cruise control
- Top of the range radio with sat nav
- Manual air conditioning
- Lounge dashboard
- Steering wheel controls
- Video camera with display integrated into the Fiat dashboard

FR

Châssis de série

- Planche de bord haut de gamme
- Double airbag
- Régulateur de vitesse
- Radio haut de gamme avec navigateur
- Climatiseur manuel
- Panneau de commande salon
- Commandes au volant
- Caméra vidéo avec écran intégré à la planche de bord Fiat

CELLULA DI SERIE



- **Cruise and control limiter**
permette di impostare la velocità di crociera mantenendola costante.
- **Traction+**
in caso di fango, neve, sabbia o erba, toglie coppia alla ruota motrice che slitta e la trasferisce a quella con maggiore presa.
- **Hill holder**
mantiene fermo il veicolo nelle partenze in salita.
- **Hill descent control**
aiuta a mantenere la velocità desiderata senza dover azionare continuamente il freno.

EN

Standard living area

- **Cruise control limiter**
Cruise control allows you to set the cruising speed and keep it constant.
- **Traction+**
Where there is mud, snow, sand or grass, it removes torque from the driving wheel that is slipping and transfers it to the wheel with greater traction.
- **Hill holder**
Keeps the vehicle steady during hill starts.
- **Hill descent control**
Helps to maintain the desired speed without having to continuously use the brake.

FR

Cellule de série

- **Régulateur et limiteur de vitesse**
Le régulateur de vitesse permet de configurer la vitesse de croisière et de la maintenir constante.
- **Traction+**
En présence de boue, de neige, de sable ou d'herbe, réduit le couple sur la roue motrice qui glisse et le transfère à la roue ayant la meilleure prise.
- **Système anti-recul**
Maintient le véhicule à l'arrêt lors d'un démarrage en côte.
- **Système de contrôle en descente**
Aide à maintenir la vitesse souhaitée sans avoir à actionner le frein en permanence.

MOTORHOME

Chassis Fiat Ducato X2 / 90 AL-KO



AMERICA 1



CILINDRATA - DISPLACEMENT - CYLINDRÉE	2,3 / 3,0
POTENZA - POWER - PUISSANCE	130 - 150 / 180
LUNGHEZZA - LENGTH - LONGUEUR	740
LARGHEZZA - WIDTH - LARGEUR	236
ALTEZZA - HEIGHT - HAUTEUR	297
POSTI OMOLOGATI PLACES CARTE GRISE - POSTI OMOLOGATI	3 4 (con TRUMA Combi 6)
POSTI LETTO - NUMBER OF BEDS - PLACES DE COUCHAGE	3
SPESSORE PARETI - WALL THICKNESS - ÉPAISSEUR DES CLOISONS	50
RIVESTIMENTO PARETI / TETTO WALL / ROOF COVERING - REVÊTEMENT DES CLOISONS / DU TOIT	ALUFIBER / VETRORESINA - POLYESTER ALUFIBER / FIBREGLOSS - POLYESTER FIBRE D'ALUMINIUM / RÉSINE DE VERRE - POLYESTER
ISOLAMENTO PARETI - WALL INSULATION - ISOLATION DES CLOISONS	STYROFOAM



AMERICA 2



CILINDRATA - DISPLACEMENT - CYLINDRÉE	2,3 / 3,0
POTENZA - POWER - PUISSANCE	130 - 150 / 180
LUNGHEZZA - LENGTH - LONGUEUR	740
LARGHEZZA - WIDTH - LARGEUR	236
ALTEZZA - HEIGHT - HAUTEUR	297
POSTI OMOLOGATI PLACES CARTE GRISE - POSTI OMOLOGATI	4
POSTI LETTO - NUMBER OF BEDS - PLACES DE COUCHAGE	4
SPESSORE PARETI - WALL THICKNESS - ÉPAISSEUR DES CLOISONS	50
RIVESTIMENTO PARETI / TETTO WALL / ROOF COVERING - REVÊTEMENT DES CLOISONS / DU TOIT	ALUFIBER / VETRORESINA - POLYESTER ALUFIBER / FIBREGLOSS - POLYESTER FIBRE D'ALUMINIUM / RÉSINE DE VERRE - POLYESTER
ISOLAMENTO PARETI - WALL INSULATION - ISOLATION DES CLOISONS	STYROFOAM



AMERICA 3



CILINDRATA - DISPLACEMENT - CYLINDRÉE	2,3 / 3,0
POTENZA - POWER - PUISSANCE	130 - 150 / 180
LUNGHEZZA - LENGTH - LONGUEUR	740
LARGHEZZA - WIDTH - LARGEUR	236
ALTEZZA - HEIGHT - HAUTEUR	297
POSTI OMOLOGATI PLACES CARTE GRISE - POSTI OMOLOGATI	4
POSTI LETTO - NUMBER OF BEDS - PLACES DE COUCHAGE	4
SPESSORE PARETI - WALL THICKNESS - ÉPAISSEUR DES CLOISONS	50
RIVESTIMENTO PARETI / TETTO WALL / ROOF COVERING - REVÊTEMENT DES CLOISONS / DU TOIT	ALUFIBER / VETRORESINA - POLYESTER ALUFIBER / FIBREGLOSS - POLYESTER FIBRE D'ALUMINIUM / RÉSINE DE VERRE - POLYESTER
ISOLAMENTO PARETI - WALL INSULATION - ISOLATION DES CLOISONS	STYROFOAM



BEAUTY CONCEPT - BAGNO

AMERICA 1

BEAUTY CONCEPT - WC AREA · BEAUTY CONCEPT - ZONE WC



Armadio con scorrimento elettrico. Armadio chiuso.

EN
Sliding wardrobe with electric system.
Closed wardrobe.

FR
Penderie coulissante électriquement.
Penderie fermée.



Armadio con scorrimento elettrico. Armadio aperto.

- 1 Zona wc
- 2 Armadio elettrico
- 3 Doccia

EN
Sliding wardrobe with electric system.
Open wardrobe.. 1. WC Area - 2. Sliding wardrobe with electric system - 3. Shower

FR
Penderie coulissante pour dégager la douche 1. Zone WC - 2. Penderie coulissante électriquement - 3. Douche



LIVING - DIVANO POSTERIORE

AMERICA 1

LIVING - REAR COUCH · LIVING - SALON ARRIÈRE



Divano posteriore
con trasformazione letto
a movimento elettrico.

EN
Couch in the back allowing bed
transformation due to electric movement.

FR
Salon arrière transformable
électriquement en lit.





LIVING - DIVANO POSTERIORE RELAX

AMERICA 1

LIVING - RELAX AREA IN THE REAR COUCH · LIVING - CONFORT AREA DANS LE SALON ARRIÈRE



Optional

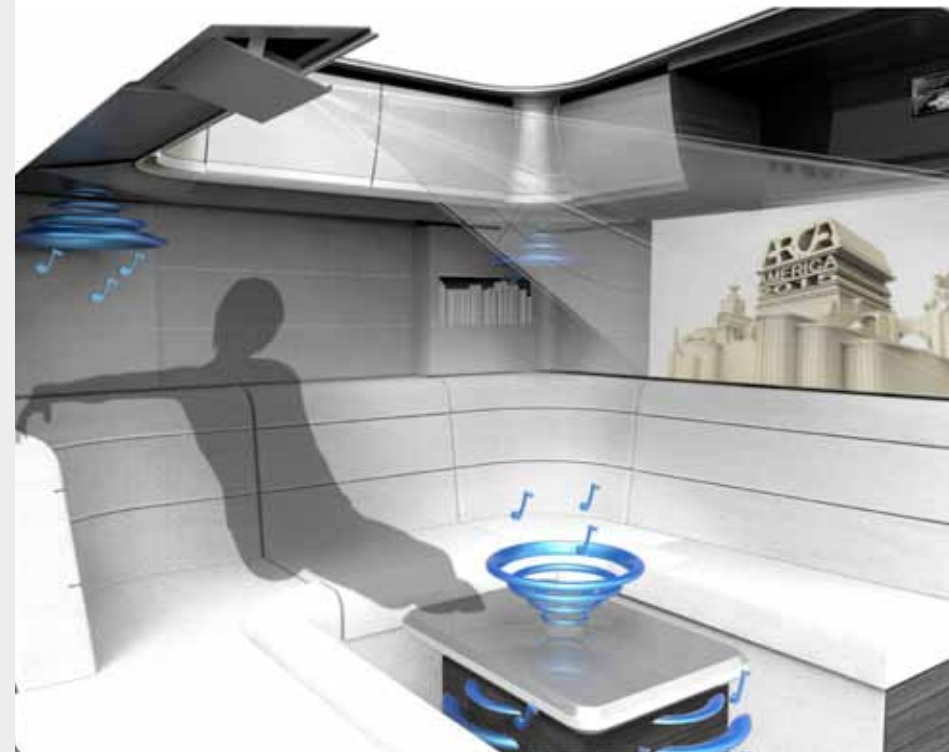



LIVING - RELAX

AMERICA 1 - 2 - 3

LIVING - RELAX · LIVING - CONFORT



Seduta con trasformazione comfort (movimento elettrico)

- 1 | Scorrimento elettrico di seduta e schienale
- 2 | Poggiatesta regolabili in altezza

EN

Couch with electric confort system
1. Electric system for seat and backrest
2. Headrest Adjustable in height

FR

Banquette réglable électriquement assise et dossier pour plus de confort
1. Banquette réglable électriquement assise et dossier pour plus de confort
2. Appui tête réglable en hauteur





ELEMENTI STRUTTURALI

STRUCTURAL ELEMENTS · ÉLÉMENTS DE STRUCTURE



Bandelle e frontale in VTR.

EN
Skirt and front in FG.

FR
Bas de caisse et face avant
en résine de verre.



Posteriore monoblocco in VTR.

EN
Rear FG one-piece.

FR
Arrière monobloc en résine de verre.



Fari anteriori FULL LED.

EN
Full led headlights.

FR
Phares avant entièrement à led.



Oscurante parabrezza elettrico.

EN
Electric windscreen shade.

FR
Occulteur de pare-brise électrique.



Letto basculante elettrico:
1500 x 1930 mm.

EN
Electric drop-down bed: 1500 x 1930mm.

FR
Lit de pavillon électrique: 1500 x 1930 mm.

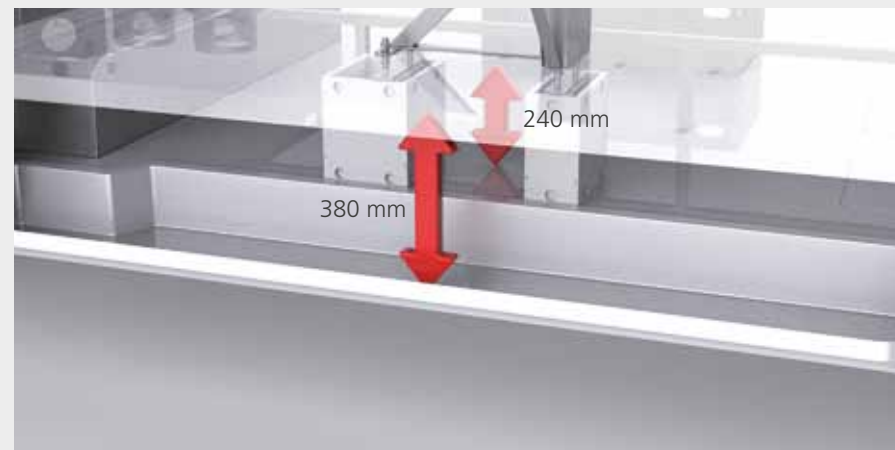

Vasca integrata in VTR per
maggiore stivaggio.

EN
Integrated FG tray for more storage.

FR
Bac intégré en résine de verre
pour plus de rangement.





STRUTTURE

STRUCTURES · ÉLÉMENTS DE STRUCTURE



Distribuzione bilanciata del peso.
Centro di gravità basso.
Struttura leggera.

EN
Balanced weight distribution. Low centre of gravity.
Lightweight structure.

FR
Distribution équilibrée du poids. Faible hauteur du centre de gravité. Légèreté de la structure.

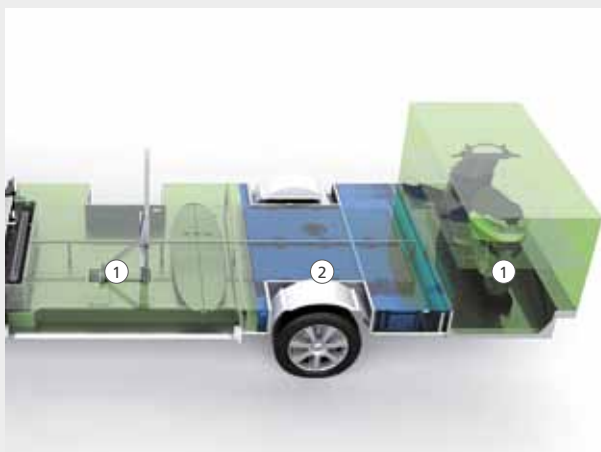

- 1 | Spazio stivaggio
- 2 | Spazio tecnico

EN
1. Storage space
2. Technical space

FR
1. Espace de rangement
2. Espace technique



Nuovo concetto di assemblaggio delle strutture: alta resistenza, giunte del tetto anti-infiltrazione, alta protezione agli agenti atmosferici.

EN
A new concept of structural assembly: high resistance, anti-seepage roof joints, high protection against weathering.

FR
Nouveau concept d'assemblage des éléments de structure: haute résistance, joints de toit anti-infiltration, protection élevée contre les agents atmosphériques.



ARCA WALL

ARCA WALL · PAROIS ARCA WALL

Struttura senza legno
Alufiber esterno VTR interno
Superfici esterne planari e brillanti
Alta resistenza agli impatti
Alto isolamento acustico
Alto isolamento termico

MATERIALI

MATERIALS · MATÉRIAUX

VTR · FG · RÉSINE DE VERRE

VTR · FG · RÉSINE DE VERRE

VTR · FG · RÉSINE DE VERRE

ALUFIBER

VTR · FG · RÉSINE DE VERRE

STYROFOAM

VTR · FG · RÉSINE DE VERRE

SPESSORI

THICKNESSES · ÉPAISSEURS

50 mm

50 mm

53 mm

23 mm

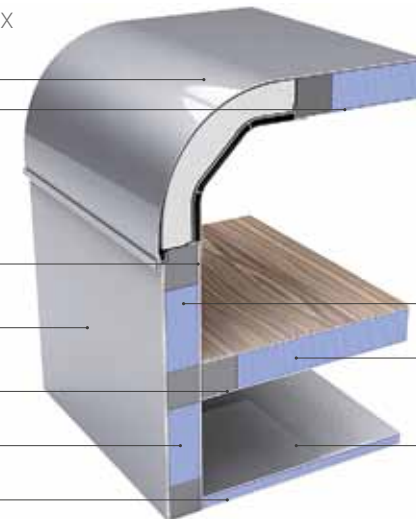

EN

Wood-free structure
Alufiber exterior, FG interior
Glossy planar external surfaces
High impact resistance
High level of soundproofing
High level of thermal insulation

FR

Structure sans bois
Fibre d'aluminium à l'extérieur,
résine de verre à l'intérieur
Surfaces externes planes et brillantes
Haute résistance aux chocs
Isolation acoustique élevée
Isolation thermique élevée



SISTEMI

SYSTEMS · SYSTEMES

Distribuzione impianto ALDE
cellula-cabina

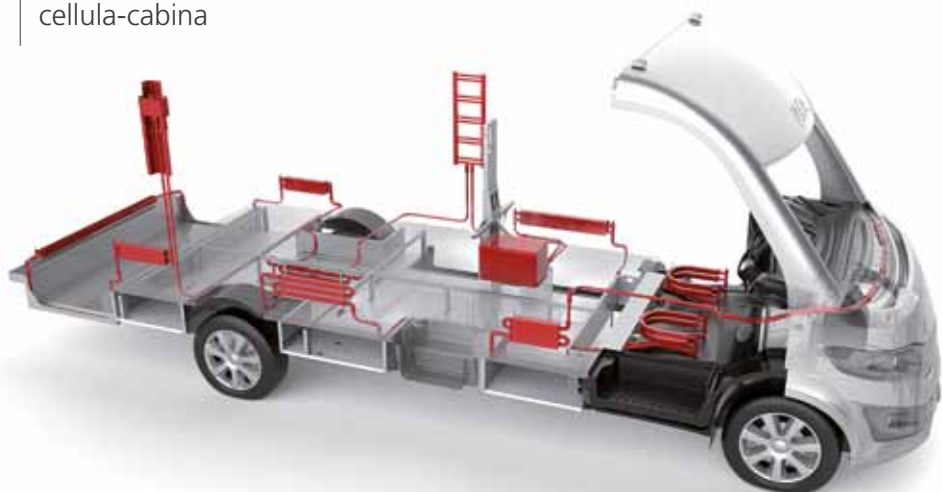

EN
Living area/cab ALDE heating system distribution

FR
Distribution chauffage cellule-cabine ALDE

Impianto cabina integrato con la cellula
Volume doppio pavimento riscaldato



EN
Cab system integrated with the living area
Double the volume floor heating

FR
Installation de cabine intégrée à la cellule
Volume du double sol chauffé



STILE E ARREDO

STYLE AND DECOR · STYLE ET AMÉNAGEMENTS

MOBILIO

FURNITURE · MOBILIER



NOCE MACADAMIA

TAPPEZZERIA

UPHOLSTERY · REMBOURRAGE

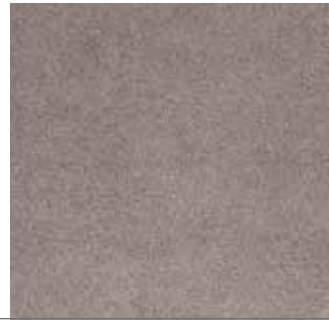

DREAM
Vera Pelle grigia

EN
Grey genuine leather

FR
Cuir véritable gris



FREEDOM
Ecopelle bianca
Impunture marroni

EN
White ecoleather
Brown stitching

FR
Cuir écologique
blanc piqué marron

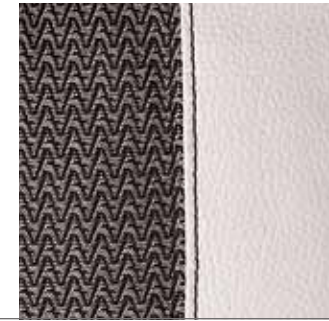

STARS
Tessuto Texture Arca
Ecopelle bianca

EN
Arca textured fabric
White ecoleather

FR
Tissu à texture Arca
Cuir écologique blanc

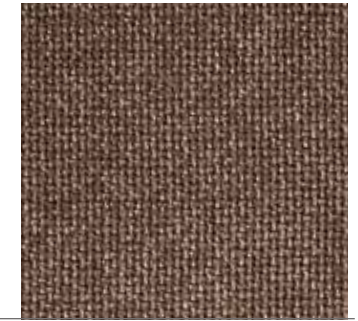

NATURE
Tessuto marrone

EN
Brown fabric

FR
Tissu marron



LA CERTEZZA DI VIAGGIARE AL SICURO

THE ASSURANCE OF SAFE TRAVEL · LA CERTITUDE DE VOYAGER EN SÉCURITÉ

Una rete capillare di concessionari altamente qualificati,
per un servizio di assistenza su misura.

EN

An extensive network of highly qualified dealers, with tailor-made after-sales.

FR

Un réseau dense de concessionnaires hautement qualifiés, pour un service d'assistance sur mesure.

Cerca il concessionario più vicino a te sul sito arcacamper.it

EN

Find your nearest dealer at arcacamper.it

FR

Recherchez le concessionnaire le plus proche de chez vous sur le site arcacamper.it





ALBUM DI VIAGGIO

TRAVEL ALBUM · ALBUM DE VOYAGE



Per i tuoi ricordi, le tue emozioni, i tuoi viaggi:
un'immagine che ti accompagnerà ovunque tu vada,
come il tuo veicolo Arca.

EN
For your memories, emotions, travels: a memento that will accompany you wherever you go,
like your Arca vehicle.

FR
Pour vos souvenirs, vos émotions, vos voyages: une photo qui vous accompagnera où que vous alliez,
en compagnie de votre véhicule Arca.



Tutti i marchi citati o rappresentati fotograficamente nel catalogo appartengono ai relativi depositari. Arca si riserva il diritto di apportare ai veicoli e ai relativi documenti informativi, in qualsiasi momento e senza preavviso, quelle modifiche che ritenesse utili per qualsiasi esigenza di carattere costruttivo o commerciale. Foto e disegni non contrattuali. Alcuni dati concernenti le caratteristiche tecniche e di omologazione possono variare. Le dimensioni, i pesi e i posti omologati sono soggetti a variazione a seconda del modello, della motorizzazione e della dotazione di optional e accessori.

Arca Camper S.p.A. | Une Entreprise Trigano

Via Val D'Aosta 4,
53036 Poggibonsi - Siena
info@arcacamper.it

arcacamper.it

EN

All trademarks mentioned or represented photographically in the catalogue belong to their respective owners. Arca reserves the right to make any changes it deems necessary to the vehicles or related information documents to meet any manufacturing or commercial requirement, at any time and without notice. Photos and drawings are not contractual.

Data concerning the technical features and approval specification may vary.

The dimensions, weights and approved seats may be subject to change depending on the model, the engine and the optional extras and accessories supplied.

FR

Toutes les marques citées ou représentées sur les photos du catalogue appartiennent à leurs dépositaires respectifs. Arca se réserve le droit d'apporter aux véhicules et à leurs documents d'information, à tout moment et sans préavis, les modifications qu'elle considérera comme utiles, pour toute raison liée à la construction ou d'ordre commercial. Photos et dessins non contractuels. Certaines données concernant les caractéristiques techniques ou d'homologation sont susceptibles de varier.

Les dimensions, les poids et les places homologuées sont sujets à variation en fonction du modèle, de la motorisation et de l'équipement en options et accessoires.

Photo
F. Zattarin
Archivio Arca Camper S.p.A.

Artwork
o-zone.it

Printed in Italy 09/2015
graficheantiga.it



Arca Camper S.p.A. | Une Entreprise Trigano

arcacamper.it
